

The Post Office Electrical Engineers' Journal

VOL 62 PART 2 / JULY 1969



Standardization of the Large Cordless-Type P.A.B.X.—P.A.B.X. No.4

R. A. NOTMAN, C.ENG., M.I.E.E.†

U.D.C. 621.395.26:389.6

Since 1958, all requirements for large cordless-type p.a.b.x.s were met by the telephone equipment manufacturers supplying their own designs which were approved by the Post Office. A standard p.a.b.x. has now been developed and some of the features of the new design are described in this article.

The p.a.b.x. should find its greatest application in the 300–1200 line range but some very large installations up to 7,000 lines, have been planned.

INTRODUCTION

A Post Office standard p.a.b.x. for large installations, i.e. over 50 extensions, was introduced into service as long ago as 1950 and made use of a cord-type manual switchboard. It is known as the P.A.B.X. No. 3¹ and is widely in use today. However, the advantages of a cordless switchboard, e.g. easier and speedier operator control and greater scope for a more functional and attractive design of manual position, made it worthwhile to standardize a cordless system as well. Five proprietary designs² by the principal manufacturers were in existence; each offered a variety of facilities and were approved by the Post Office for use by subscribers. These pre-standard versions were well received and confirmed public interest in the cordless system, but the inevitable differences between them, and the maintenance problems which arose in coping with the five variants made the development of a standard version more urgent.

The new design had to be capable of offering the facilities of the existing types of p.a.b.x., introduce a number of new features and eliminate the known weaknesses.

The project was undertaken jointly by the p.a.b.x. manufacturers and the Post Office as a British Telephone Technical Development Committee development with Standard Telephones and Cables, Ltd. as the liaison manufacturer. The standard P.A.B.X. No. 4 was introduced from June 1966. Concurrently with the design of the main p.a.b.x., a register-controlled satellite was designed to meet the growing requirements of large installations for fully-integrated private telephone networks.

Customers requiring a large-size p.a.b.x. negotiate with one of the equipment manufacturers and once installed, the Post Office carries out a program of acceptance testing similar to that used at public exchanges as a preliminary to the call-through test and opening of the exchange to traffic. The Post Office then maintains the exchange.

EQUIPMENT PRACTICE

Well-proven techniques of public-exchange practice have been followed for the automatic equipment which consist of jack-in relay-sets, uniselectors, and two-motion switches of the 4000-type, mounted on open-type racks. Conventional equipment was used because the fairly complex facilities were required as quickly and cheaply as possible and development costs were minimized.

One of the difficulties encountered in standardizing p.a.b.x.

equipment is the varying accommodation offered by customers for housing the apparatus, and for this reason standardization has been limited to circuits and components only. The manufacturers retain freedom to adopt their own design of rack layout, and to some extent in the method of inter-connecting the equipment, provided that Post Office standards are met. Nevertheless, all manufacturers have found it expedient to aim at a more or less uniform grouping of equipment, based on a four-rack arrangement of line and final-selector equipment, group selectors, line-terminating relay-sets and position-equipment for the cordless switchboard. In addition, there is usually a miscellaneous equipment rack for the ringer and miscellaneous items of equipment.

The make up of position-equipment racks depends on the availability to be provided, but each rack will normally carry access equipment for one or two switchboard positions.

Standard ringing supplies and tones are derived from a Dynamotor No. 44A for all but the largest installations, at which a Dynamotor No. 41A may be necessary. Provision is made for a second machine and automatic change-over equipment where the size of the installation warrants it or where there is need for additional system security.

TRUNKING

Two independent switching trains are used, one to route extension to extension and directly-dialled outgoing traffic and the other, the incoming train, to deal with operator-extended and directly-dialled incoming calls. The local switching train is similar in many ways to that designed for the P.A.B.X. No. 3 in that it employs 50-point uniselectors as line finders and 100-outlet group and final selectors. The final selectors incorporate a divided-feed transmission bridge.

The incoming switching train has several features not generally found in step-by-step switching practice, mainly because the transmission bridge and the ringing and supervisory elements are located in the line-terminating relay-sets rather than in the final selectors. This allows a relatively simple switch train with a straight-through transmission path from the relay-set to the called extension. Supervisory indications are signalled to the relay-sets on auxiliary wires making a total of six wires per outlet on the group-selector multiple.

The divided-feed transmission bridge in the line-terminating relay-set provides a focal point for the p.a.b.x. and a d.c. barrier between the public network and the internal switching operations. Transmission problems are eased in that feed current to extensions does not depend on exchange-line length and control of ringing from the relay-set simplifies supervision. The ring-when-free facility is also controlled from the relay-set. Part of a typical trunking diagram for a P.A.B.X. No. 4 is shown in Fig. 1.

† Mr. Notman is in Test and Inspection Branch, Purchasing and Supply Department, but was formerly in Exchange Facilities Division, Telecommunications Development Department, Telecommunications Headquarters.

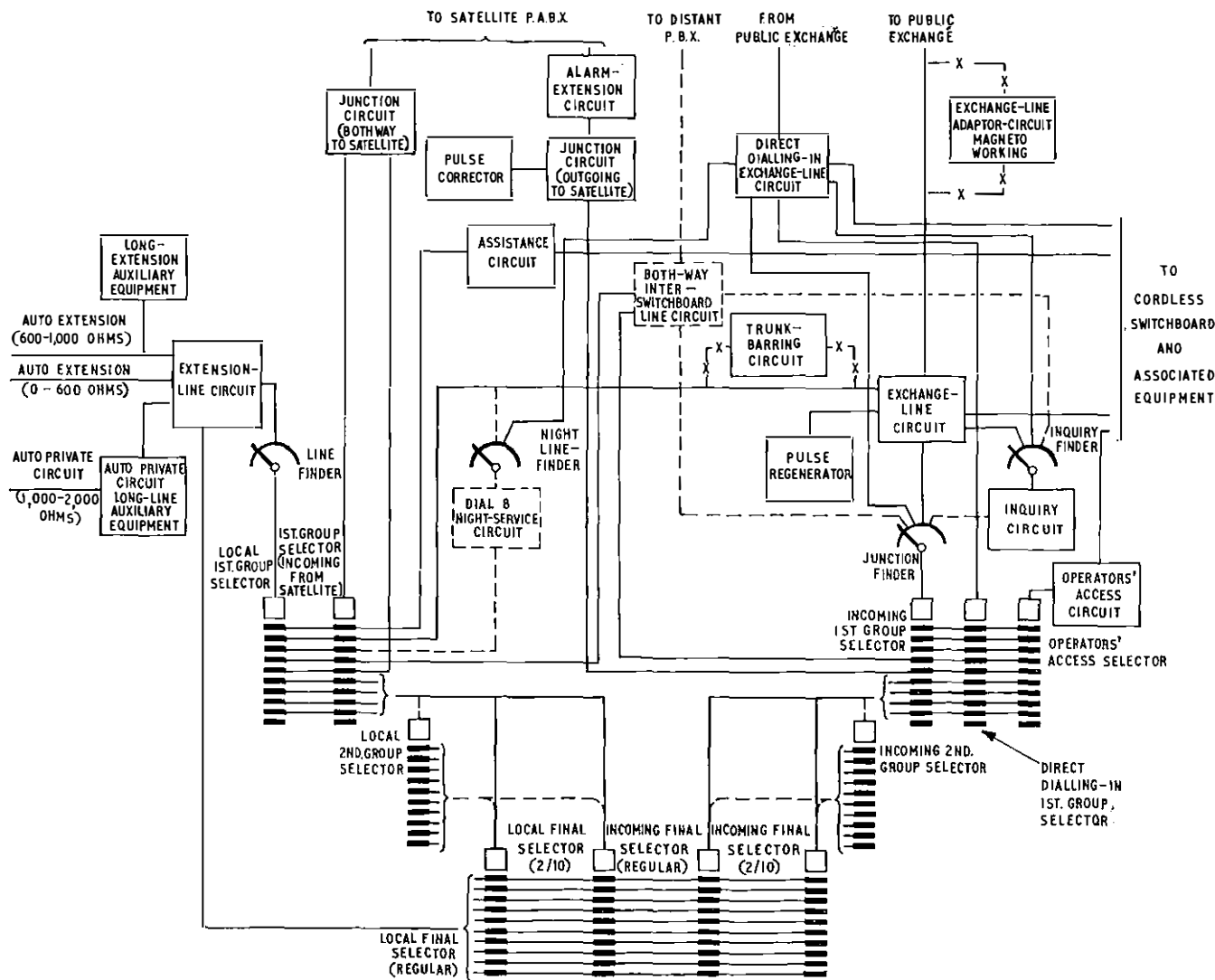

FIG. 1—Trunking diagram of the P.A.B.X. No. 4 with the D.D.I. facility

A 3-digit, 4-digit or mixed 3- and 4-digit numbering scheme can be employed. The linefinders are Type-2 uniselectors serving 50 lines per group.

The exchange lines and inter-p.b.x. lines, other than Signalling System A.C. No. 13 (S.S.A.C. No. 13) circuits, are arranged in 20-line groups with provision for a maximum of 4 inquiry circuits. Thus, each group can be accommodated on the banks of a 25-point junction finder. Generally, both-way circuits are used and 12-16 junction finders suffice for 20 circuits. The junction finders are directly connected to incoming first selectors and form the start of the incoming train. At larger installations, where exchange lines are provided on a unidirectional basis, incoming and outgoing circuits are mixed within a group.

Incoming traffic from satellites is passed via both-way-junction relay-sets to directly-connected first group selectors which have a common multiple with the local switching train.

The local switching train gives the extensions access to the public exchange from level 9 of the local first group selectors in the conventional manner, level 7 is generally allocated for inter-p.b.x. traffic and level 8 is used for one form of night service. The remaining levels serve the p.b.x. local-numbering scheme and provide satellite access. Level 0 routes assistance traffic to the cordless switchboard.

The position-circuit and connecting-circuit finders (Fig. 2)

are both 50-point finders, the former being a motor unisector. This provides for a maximum of 50 circuits which can be exchange lines, inter-p.b.x. lines or assistance circuits associated with a position for answering or originating calls. If position availability greater than 50 circuits is required, additional finders can be added, and a wiper-switching circuit used to select the required finder.

Direct-Access Routings

An important advantage of the cordless system is that operator effort can be reduced to a minimum by designing the position equipment in such a way that calls are answered and manipulated in a few seconds, leaving subsequent supervisory operations to be looked-after automatically. Operator effort is further reduced in that all outgoing traffic may be directly dialled from the extensions, and, if the optional facility of direct dialling-in from the public exchange is added, all incoming calls may also be completed without operator intervention. A brief outline of the routings available to extensions by direct dialling is given below.

Extension-to-Extension Calls

A conventional linefinder system gives access to the first selector. The linefinder start circuit, in common with all similar start circuits within the p.a.b.x., incorporates a start-dis-

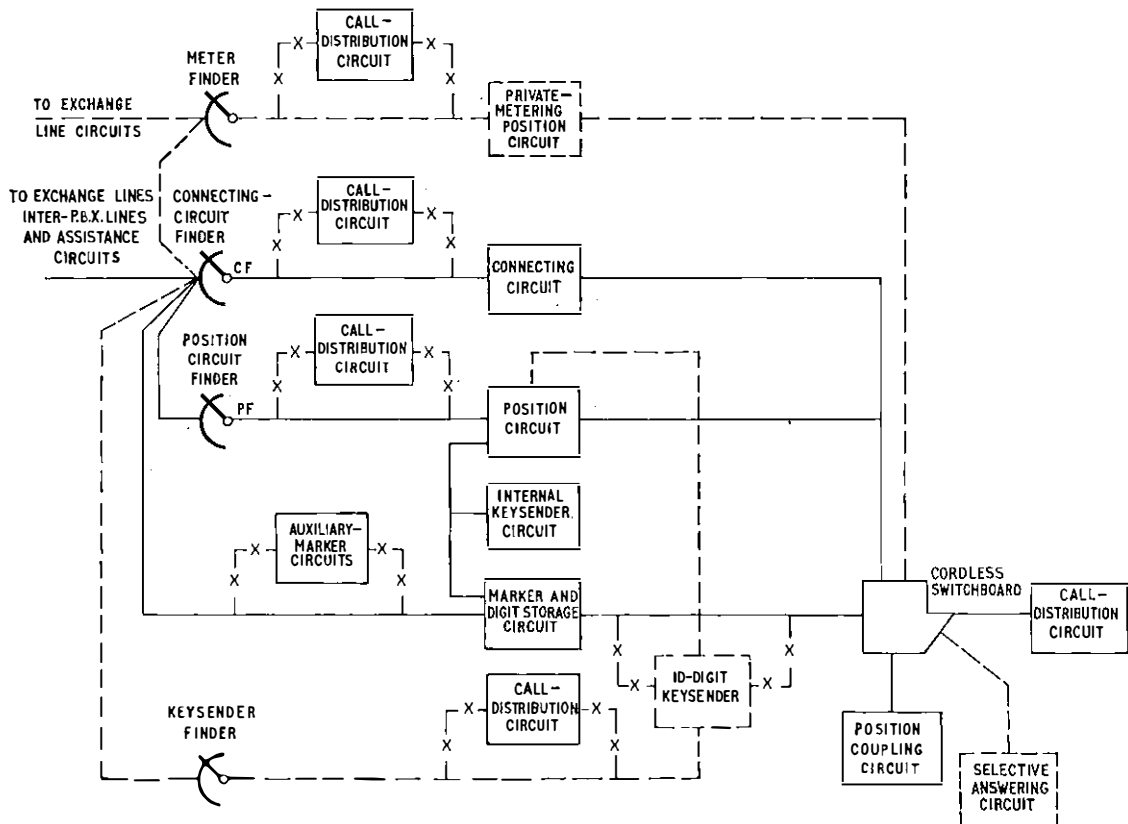

FIG. 2—Block schematic diagram of the cordless switchboard and associated equipment

tribution uniselector to ensure that a faulty first selector does not interrupt the start chain. Standard loop-disconnect pulses position the selectors. Control of ringing and ringing tone is located in the final-selector transmission bridge and first-party release is given.

Extension-to-Exchange Calls

Calls to the public exchange are normally set up by direct access from level 9 of the local first group selectors, but can be completed if necessary via the switchboard. A variety of trunk-barring arrangements are available to restrict the dialling range on level 9 according to local requirements. This is predetermined for each extension by strappings on the line circuit. The trunk-barring relay-sets can be associated with the exchange-line relay-sets and these employ Type-4 uniselectors to count the initial digits dialled. If a barred code is received, the trunk-barring relay-set inhibits further dialling and causes number unobtainable (N.U.) tone to be returned to the caller. Non-selective barring of all outgoing calls can be arranged by omitting a strap in the line circuit. In this case the first selector switches to the eleventh step and returns N.U. tone. Provision is also made for key-controlled trunk-barring whereby operation of a Yale-type switch-lock on the telephone applies the barring.

Assuming that access is allowed, the selector hunts over level 9 for a free exchange-line relay-set which in turn seizes the line circuit at the public exchange and dial tone is returned. During the setting up and clearing down of calls, the exchange-line relay-set in any p.a.b.x. has an exacting role to play, in that it must function as an auto-auto relay-set terminating a bothway junction, and must interwork with a simple line circuit at the public exchange. In the P.A.B.X. No. 4, standard earth-calling principles are used to call the public exchange, i.e. earth is applied to the B-wire of the exchange line to operate the line relay in the line circuit. The public exchange returns battery on the B-wire and earth on the A-wire, when

a first selector has been seized. The exchange-line relay-set can discriminate between outgoing and incoming calls and does not depend on the maintenance of the conditions from the public exchange for holding. The element in the exchange-line relay-set which monitors the conditions at the public-exchange end of a connexion has been arranged to respond to signals of either polarity on both wires of the exchange line to suit all types of public exchange.

All extension telephones are of the 700-type fitted with a regulator, and provision has been made to limit the current flowing in the extension line to a value comparable with that received on an equivalent direct exchange line, otherwise the regulator tends to degrade transmission on short extension lines when connected to long exchange lines. At installations with exchange lines exceeding a specified transmission equivalent resistance (t.e.r.), resistors will be fitted in the transmission bridges of the p.a.b.x. to reduce the extension feed current to the optimum value.

Extension-to-Inter-Switchboard Line Calls

Direct-access calls to distant p.b.x.s are routed via local first-selector levels to the inter-switchboard line circuit. If necessary, second-selector levels may be used. Sometimes it is necessary to provide a large number of routes each with only one or two circuits and, to prevent waste of outlets on the access levels, a 2-digit group selector has been developed to provide this facility economically.

This selector steps vertically in response to the first digit and horizontally to the second digit received. It can also function as a normal 100-outlet group selector by cutting-in and automatically hunting for a free circuit after the first digit. The choice of 1-digit or 2-digit working is a pre-set condition on the levels. In practice, routes with many circuits are allocated single-digit levels and routes with one or two circuits are given 2-digit codes. A type of group hunting is employed on the 2-digit levels to allow limited hunting for a free circuit

within a small group. Provision is made for through dialling to distant p.a.b.x.s over routes equipped for loop dialling, single commutation d.c. (S.C.D.C.) and 1 v.f. signalling (S.S.A.C. No. 13). The S.S.A.C. No. 13 system provides for pause-free dialling into distant p.a.b.x.s, i.e. extension users dial the routing digits to gain access to an S.S.A.C. No. 13 link and then dial the remaining digits without the usual pause to listen for second dial tone. Under pause-free dialling conditions, the hunting time of a junction finder could be an embarrassment and accordingly S.S.A.C. No. 13 links are always directly connected to first selectors at the incoming end. Auto-manual working is available using A-wire earth signalling and automatic generator signalling (a.g.s.). All the above mentioned systems are suitable for bothway working; a.g.s. is restricted to working between P.A.B.X.s No. 4.

The line-terminating relay-sets for the inter-switchboard circuits provide the hold-for-inquiry feature and calls can be transferred to distant p.b.x.s (if permitted). The inter-switchboard relay-sets follow the same circuit principles as the exchange-line relay-sets and incorporate a divided-feed transmission bridge along with ringing and supervisory elements.

Tandem Connexions

Incoming calls from distant p.b.x.s may be routed through incoming first selectors to the appropriate level for access to an outgoing inter-switchboard route, thereby using the p.a.b.x. as a private tandem switching centre.

Inquiry and Transfer

Operation of the telephone-instrument button on an established exchange or inter-p.b.x. line call, starts an inquiry finder (uniselector), shown in Fig. 1, hunting for the line-terminating relay-set involved. When an inquiry circuit has been associated, it in turn extends a start condition to a free incoming first selector. The associated junction finder then connects the selector to the inquiry circuit and dial tone is returned to the caller. The extension user may then dial the number of any extension or the code for any inter-p.b.x. circuit. The called party is rung from the inquiry circuit and, on answering, can speak to the caller without being overheard by the distant party. A hold condition is maintained on the external call from the time of pressing the button regardless of whether the distant caller clears or not.

If a call is to be transferred, the inquirer replaces his handset and the removal of the extension loop condition causes the junction finder to hunt for the exchange line or inter-p.b.x. relay-set. The inquiry circuit and the original selector train release leaving the external call connected to the new extension. Subsequent inquiries and transfers may be carried out as desired.

CORDLESS SWITCHBOARD AND ASSOCIATED EQUIPMENT

Unless the direct-dialling-in facility is provided, all incoming calls are answered at the switchboard. As outlined earlier, up to 50 exchange lines, inter-p.b.x. lines or assistance circuits can be terminated on the banks of the connecting-circuit finders and also on the banks of the motor-uniselector position finder. Access for more than 50 circuits can be provided by adding further position finders and connecting-circuit finders and introducing the facility of call distribution. In effect this facility employs a wiper-switching circuit to select the switches serving the wanted circuit.

Three typical cordless switchboard designs are shown in Figs. 3, 4 and 5. Each manufacturer had complete freedom of design provided that the operational and maintenance requirements of the Post Office were met. That a great deal of effort was devoted to achieving elegant and well-integrated designs is borne out by the fact that all switchboards



FIG. 3—Cordless switchboard by Standard Telephones and Cables Ltd.



FIG. 4—Cordless switchboard by Ericsson Telephones Ltd.

submitted to the Council of Industrial Design received approval.

The display panels are generally of the secret type, i.e. the



FIG. 5—Cordless switchboard by GEC-AEI Telecommunications Ltd.

legends remain invisible or unobtrusive until the lamp concerned glows. This avoids clutter on the screen which could be distracting to operators, but poses problems of specular reflexion from the surface. Considerable ingenuity has been exercised in overcoming this problem. Each switchboard has a digit keyset to control its internal keysender and a KEYSEND key to switch the keyset to the external keysender (if provided). All switchboards are provided with a dial as security against keysender failure. Since its appearance does not harmonize well with the rectilinear lines of the switchboard, the dial is so mounted that it is out of sight when not in use. The general layout was specified by the Post Office for operational reasons, but some variations in detail will be found.

Taking for example Fig. 3, the keyshelf layout consists of two rows of push-button keys made up of illuminated selective ANSWER keys on the left, connecting-circuit SPEAK and HOLD keys in the centre and the digit keyset on the right. Also on the left (top row) are keys for LINE IDENTIFICATION, TRANSFER, SUPERVISOR and the line-splitting keys, SPEAK EXCHANGE and SPEAK EXTENSION. The DIAL RELEASE, and RECALL keys form a group on the extreme right. The KEYSEND and CANCEL keys are included in the keyset group.

The display lamps are located in cells behind a translucent panel. The supervisory group, RINGING, BUSY and WAITING occupy the area immediately above the connecting circuit keys in the lower centre of the display. The pilot group, i.e. LISTEN-IN, MONITOR, SUPERVISOR, EMERGENCY, PILOT, TRANSFER and POSITION FAIL occupy a central position. The upper centre of the display contains the tens and units lamps for the line-identification indication. These groups are flanked right and left by the calls-waiting indicator consisting of a thermometer-type illuminated column with a numeric indication. Up to 30 calling-group lamps occupy the left of the display. The corresponding busy-group lamps occupy the right of the panel. Also on the right, or alternatively with the pilot group in the centre, are lamps to indicate KEYSEND, SENDING, ROUTE ENGAGED, or DIAL.

OPERATION OF THE CORDLESS SWITCHBOARD

Operator-Answered Calls

Either common answering or selective answering may be provided. With common answering, a common pilot lamp, and/or an indication from the calls-waiting display, denotes that one or more calls are waiting to be answered. No indication of the type of call waiting is given at this stage. Operation of a SPEAK key on a free connecting circuit, followed by depression of the COMMON-ANSWER bar or key, causes the finder on the selected connecting circuit to hunt for a marking condition corresponding to a calling line. This finder then extends a marking condition via the finder multiple to the corresponding outlet on the position finder bank. The position finder then drives and connects the position to the calling line. An indication of the type of call, derived from the banks of the position finder, now appears in the group identification section of the lamp display.

If selective answering is used, the incoming traffic is divided into groups according to the class of traffic, e.g. both-way exchange line, assistance, and each group is allocated an illuminated plunger-type key. Thus the operator can exercise some choice in the type of call to be answered. The circuit operation is similar to that outlined for common answering except that an indication of the type of call is given before answer. The calls-waiting display operates with either type of answering. The lamps are switched into circuit by a chain of current-sensitive relays energized by a current proportional to the number of lines calling.

While a call is being handled on the position, the group-identification indication may be supplemented by identification of the actual line within the group. This is displayed by a group of tens and units display lamps in the centre of the panel and illuminated by operation of the LINE-IDENTIFICATION key.

Extending Incoming Calls to Extensions

On receiving a request for an extension, the operator merely uses the keyset to key in the digits of the extension number and restores the SPEAK key to retire from the circuit. The digit-storage circuit associated with the internal keysender enables the digits to be keyed in rapidly and pulsed out to the incoming selector train at 10 p.p.s. via the keysender. As each successive switching stage is reached, a proceed-to-send signal in the form of an earth on the positive wire is returned to the keysender, thereby speeding up completion of calls and avoiding the need for an arbitrary inter-digital pause.

Supervision

The main function of the connecting circuit is to provide supervision within the p.a.b.x. and because it is effectively in parallel with the circuit to be supervised, it is not used to connect the call in the generally understood sense. Certain public exchanges return a reversal to the p.a.b.x. when the called subscriber answers, but this is by no means universal and could not be relied upon for supervision. Thus, only tone supervision of the external side of a call can be given.

A high standard of internal supervision is provided using three lamps per connecting circuit to indicate primarily, ringing, busy and waiting. When an incoming call is being extended, the operator's telephone-set remains connected to the external side of the call. This means that while it is necessary to rely on lamp supervision to indicate the condition of the extension, it does ensure that p.a.b.x. tones are not heard by outside callers. This requirement is being relaxed to the extent that ring tone will in future be returned to outside callers.

Normally supervision of a call ceases when the called extension answers. The call releases automatically from the switchboard and the connecting circuit becomes free. If,

however, it is desired to retain supervision of the call beyond this stage, the connecting-circuit HOLD key is operated and the supervisory lamps then continue to indicate the condition of the call.

Further supervisory indications are given by a flashing waiting lamp (750 ms on, 750 ms off) to call in the operator and a similar flashing signal in conjunction with a steady glow on either the BUSY or WAITING lamp warns that the call has remained in the ringing-out or busy condition for 30 to 60 seconds.

Outgoing Calls from the Switchboard

The majority of outgoing calls from the p.a.b.x. are completed automatically by extensions, but certain extensions may be barred from dialling beyond the p.a.b.x. numbering range or may wish to have their calls set up for them. They then dial the assistance code (normally 0) and ask the operator to complete the call. Fig. 1 shows that level 0 traffic is routed to the switchboard via the assistance circuits. Calls are signalled to the operator either on the common pilot lamp or on the lamp associated with the assistance answering key, according to the answering system employed. Such calls cannot be completed on demand and the operator sets up the outgoing call and reverts it to the caller as for an incoming call.

All outgoing routes are allocated a separate identification code which must be keyed in to the marker and digit-storage circuit to mark the group of circuits from which a free line will automatically be selected. Exchange lines are generally allocated the marking code-digit 9 to line up with the direct-access digit 9 dialled by extensions to obtain the same route.

The one-out-of-ten signals from the keyset are converted into n-out-of-four signals to operate the appropriate number of storage relays in the digit-storage circuit. Contacts of these relays extend a marking earth to all circuits in the wanted group on the banks of the connecting-circuit finders. The selected connecting-circuit finder drives to the first free outlet of the group and extends a marking condition via the CF uniselector bank to the corresponding outlet on the position-finder bank. The PF uniselector in turn associates the position with the marked outlet and dial tone is returned from the exchange line. At this stage, the operator must operate the KEYSEND key to switch the keyset from the marker and digit-storage circuit to the 10-digit keysender. The keyed-in digits required to route the call in the public network are initially stored on relays and subsequently pulsed out at 10 p.p.s. under the control of an interacting relay and capacitor circuit. Standard inter-digital pauses are introduced, timed by relays.

When all digits have been keyed-in, the keyset may be reconnected to the internal keysender by a second depression of the KEYSEND key. Pulsing out continues and, when the called number answers, the operator may complete the call to the extension by again using the digit keys to key-in the extension number. The digits required to route the call internally via the incoming train are stored in the digit-storage circuit as before and pulsed out at 10 p.p.s. to step the selectors. As described for incoming calls, the selectors signal to the keysender when they are seized, to avoid the need for an arbitrary inter-digital pause. The reverted call may now be completed and the connecting-circuit SPEAK key restored.

To further reduce operating time per call the 10-digit keysender, although provided one per switchboard, is not connected directly to the exchange lines via the position circuit. A separate keysender finder is used and this ensures that the keysender may be left pulsing out its digits while the operator deals with another call. A KEYSEND lamp on the display panel indicates that pulsing out is continuing. This facility assumes greater importance if the capacity of the keysender is increased to cope with international subscriber dialled (I.S.D.) calls of up to 17 digits.

Should the operator wish to call an extension when there is no outside call to be extended, she must use the operators' access circuit. This circuit is directly connected to a first group selector having a common multiple with the incoming first group selectors. Access is obtained by keying-in the appropriate code after selecting a free connecting circuit. The marker circuit will mark a free operators' access circuit on the banks of the connecting-circuit finder. Extension-to-extension calls cannot be completed by the operator.

Automatically-connected tandem calls have been referred to earlier, but the case of tandem inter-p.b.x. calls completed by the operator also arises. An incoming call from a distant p.b.x. will call on the switchboard in the normal way. If the call is to be extended to another p.a.b.x., the operator must key-in the digits required to step the incoming selectors to the level required and then operate the KEYSEND key to change-over to the external keysender. The necessary digits to set up the call in the distant p.a.b.x. can then be keyed. The 10-digit keysender generates inverted pulses to step the selectors in the incoming train, but conventional pulses are required to pass over inter-p.b.x. circuits to distant p.a.b.x.s, and, accordingly, as soon as an inter-p.b.x. circuit has been seized from a selector level, a signal is returned to the keysender to change it over to conventional pulsing. Supervision is given as always on the internal side of the connexion, the inter-p.b.x. line outgoing from the tandem p.a.b.x.

OPTIONAL FACILITIES

A considerable number and variety of optional facilities were developed for the pre-standard P.A.B.X.s No. 4 and equivalent facilities will be called for on the standard version. The need to provide for the more popular of these was borne in mind at the design stage and, where possible, this was done provided it did not increase the basic cost. A few of the more common optional facilities are described briefly below.

Direct Dialling-In

This facility enables outside callers to set up calls to p.a.b.x. extensions without the assistance of the p.a.b.x. switchboard operator³. Its development required consideration of the main-exchange design so that the overall pulsing performance was maintained and appropriate methods of trunking at the public exchange and the p.a.b.x. were used. Care was taken not to introduce additional transmission losses compared with corresponding operator-completed calls to ensure that transmission would not impose a limitation on the scope of direct dialling-in (D.D.I.).

The D.D.I. exchange lines form a separate incoming group of lines and terminate on D.D.I. exchange-line circuits. These are directly connected to incoming first group selectors which have a common multiple with the indirectly-connected incoming first selectors. Thereafter, the D.D.I. traffic and the operator-extended traffic share common second final selectors. Full or partial D.D.I. may be provided subject to the availability of multiple at the public exchange. The D.D.I. exchange-line relay-set incorporates a transformer-type transmission bridge with a pulse-repeating element, so designed that calls may be dialled through to the final selector in the main p.a.b.x. without pulse regeneration. The pulsing problem has been eased because the ratios of make and break used for internal pulsing have been inverted within the p.a.b.x. on the incoming switch train. This technique was originally adopted for circuit reasons, but the inversion to 66 per cent make and 33 per cent break pulses for stepping the p.a.b.x. selectors opposes the characteristic trend of pulse distortion which builds up in the public network, thereby keeping the overall distortion within acceptable limits.

The trunking arrangement is shown in Fig. 1. Normal inquiry and transfer facilities are available, and it will be seen that the D.D.I. exchange-line circuits have outlets to the banks of inquiry finders, which in turn give access to inquiry

circuits and indirectly-connected first group selectors. If a D.D.I. call is to be transferred, the answering extension will first set up an inquiry call. The earth signal from the telephone press button is detected in the D.D.I. exchange-line circuits which then associates an indirectly-connected first selector via an inquiry finder, an inquiry circuit and a junction finder. Dial tone is returned from the selector and the inquiry number can be dialled. On transfer, the clear-down condition from the D.D.I. extension, causes the junction finder to switch to the bank position to which the D.D.I. circuit is connected, and the direct-access route clears down.

The D.D.I. exchange lines form a separate group from the normal bothway route to the switchboard. Thus, if the D.D.I. route is to have access to the switchboard, a special routing must be provided. For this the switchboard is given a number on the final-selector multiple. Calls dialled in to this number result in a signal being passed back over the incoming train to the D.D.I. circuit, to cause it to set up a calling condition on the switchboard, and release the selectors used to set up the call. Any number within the range may be allocated for the operator, but the final-selector group concerned must be of the 2-10 group-hunting type, as use is made of the group-hunting feature to self-drive the wipers to the 11th step for the return of the discriminating signal. One operator number is usually sufficient as the circuit is designed for simultaneous seizure from a number of final selectors, and the holding time is short.

The range of D.D.I. has been extended to include satellite exchanges, but dialling from the public network through a main p.a.b.x. to a satellite is liable to introduce excessive pulse distortion unless a pulsing aid is introduced to counteract it. A relatively simple pulse corrector has been found adequate based on a design developed by the Plessey Co., Ltd. The correctors are associated with the outgoing junction relay-sets, but mounted separately. Setting up and periodic checking of the corrector performance requires a 10 p.p.s. source derived from a rack-mounted relay and capacitor combination.

All D.D.I. lines must have access to the switchboard for operator call-in purposes, and this applies equally to outgoing-only exchange lines used for level 9 traffic. This means that each of these lines must be given an appearance on the banks of the connecting-circuit and position-circuit multiples. In view of the small amount of assistance traffic expected from these routings, it is uneconomic to give such lines exclusive appearance on the switchboard multiples (which may necessitate the use of costly call-distribution equipment) and a call-in concentrator has been developed to provide a more economic solution. The lines concerned are terminated on the banks of a uniselector, which will switch to a calling line, and extend it to a single appearance on the switchboard multiples. Individual line identification is lost with this method.

Subsidiary Switchboards

These include supervisors' desks and inquiry desks in the switchroom, and executive units with keycalling and perhaps loud-speaking telephone facilities for selected extensions. Standard equipments are being developed to give these facilities.

Night Service

A frequently-used arrangement allows any extension to answer an incoming call after hours by dialling 8. Access to the relay-sets providing this facility is gained from level 8 of

the local first selectors, and the relay-sets have an associated uniselector which hunts for and connects the calling line. D.C. bells, each common to a number of extensions, provide the calling signal. Another system allows one extension to answer any one of a group of exchange lines on receipt of a ring on the telephone bell, or using yet another system, an extension can be directly connected to a particular exchange line. The former arrangement allows a warning tone to be superimposed on the conversation if the extension is engaged when an exchange call arrives.

Metering

Provision has been made for extension and position metering. Switchboards may have up to four cyclometer-type trip-meters and associated keys and supervisory lamps. Operation of the meter key, under a free meter, will cause the meter finder (Fig. 2) to connect the meter to the outgoing or both-way line selected for the call. A flashing meter-supervisory lamp indicates when the call is finished, so that the meter can be read and reset to zero.

Metering Units No. 3B can also be used with the bothway exchange-line circuit to detect subscriber trunk dialled (s.t.d.) metering pulses and extend d.c. signals to operate cyclometer-type extension meters. The facility can be made available to satellite extensions by extending meter pulses over the main-satellite junction to operate meters at the extension.

Switchboard Availability Greater than 50 Lines

All finder circuits associated with the cordless switchboard can be connected via the call-distribution circuit as shown in Fig. 2. The uniselectors can accommodate up to 50 circuits. If a greater availability is required, additional uniselectors are provided and relay switching used to select the uniselector serving the wanted circuit. Alternatively, limited availability can be given to each switchboard in a multi-position suite.

CONCLUSION

The P.A.B.X. No. 4 should find its greatest application in the medium size range, i.e. from 300-1,200 lines, or where a smaller but readily extensible installation is required. In this region, the cost of common equipment is spread over a reasonable number of lines so that the cost per line is moderate. Some very large installations have been planned up to about 7,000 lines. These tend to become the focal points for private networks with many inter-p.b.x. lines to other branches or out-stations. The introduction of 2-digit group-selectors should effect worth-while economies in trunking where there are a large number of inter-p.b.x. routes with few circuits per route.

ACKNOWLEDGEMENTS

The photographs of the cordless switchboards are reproduced by permission of GEC-AEI Telecommunications, Ltd., Ericsson Telephones Ltd. of the Plessey Telecommunications Group and Standard Telephones and Cables Ltd.

References

- ¹ ROCHE, J. J., Post Office Standard P.A.B.X.s, Part 3—The P.A.B.X. No. 3. *P.O.E.E.J.*, Vol. 47, p. 133, Oct. 1954.
- ² MARCHANT, P. A., An Introduction to Large Cordless P.A.B.X.s. *P.O.E.E.J.*, Vol. 53, p. 231, Jan. 1961.
- ³ TAYLOR, S. C., Direct Dialling-in to P.A.B.X. Extensions. *P.O.E.E.J.*, Vol. 61, p. 245, Jan. 1969.