

RA Roe

THE POST OFFICE *© Rd*
ELECTRICAL ENGINEERS'
JOURNAL



The Highgate Wood Electronic Telephone Exchange

S. W. BROADHURST, A.M.I.E.E.†

U.D.C. 621.395.345:621.395.722

Fifty years after the first British Post Office experimental automatic exchange was installed at Epsom, the first experimental all-electronic telephone exchange has been put into service at Highgate Wood. The exchange is the first of its type (t.d.m. switched highway) to be used for subscribers' traffic anywhere in the world.

INTRODUCTION

HIGHGATE Wood electronic telephone exchange, the first of its type (time-division multiplex switched-highway system) to be used for subscribers' traffic anywhere in the world, was accepted by the Postmaster General, the Rt. Hon. Reginald Bevins, M.P., on 12 December 1962 from Sir Thomas Spencer, Chairman of Standard Telephones & Cables, Ltd., (Fig. 1) on behalf of the five manufacturers who co-operated with the Post Office in the development, manufacture, installation and commissioning of the exchange.

In 1956 a Joint Electronic Research Committee (J.E.R.C.) consisting of the Post Office, Associated Electrical Industries, Ltd. (then Siemens Edison Swan, Ltd.), Automatic Telephone & Electric Co., Ltd., Ericsson Telephones, Ltd., The General Electric Co., Ltd., and Standard Telephones & Cables, Ltd., was set up to undertake research leading to the development of an electronic telephone switching system. At that time each member organization of the new committee had already done much work on the problems of electronic switching and several lines of approach were available. It was decided to concentrate the joint effort initially on the production of a single experimental system. Of the three possible basic switching methods available—space, time, and frequency division, only the first two appeared to be practicable, and of these a time-division multiplex (t.d.m.) system was chosen as being the most likely to exploit fully the potentialities of the new medium.

The t.d.m. system chosen was the switched-highways system. For the purpose of the experiment it was decided that a complete exchange giving all standard facilities and capable of interworking with the existing network should be built, and it was further stipulated that the exchange should be so designed that it would be demonstrably capable of extension to at least 20,000 lines. These decisions have profoundly influenced the "organization" of the system, particularly in the application of the common-control techniques used and the design of system security.

The exchange was jointly designed by a team drawn from each of the organizations, but the development and manufacture of the system was shared between the manufacturers,

each being free to use the techniques and components with which he was most familiar, or which he considered most suitable, so as to enable a comparative assessment to be made of different techniques, equipment practice and maintenance features.

For these reasons the amount and diversity of the apparatus fitted at Highgate Wood are much greater than would have been the case if the equipment had been designed solely to serve the 600 lines and junctions now in use there. No restrictions were placed on the number of power supplies nor were any new components developed specially for the experiment.

The building of a prototype model was authorized to ensure satisfactory interworking between the various sections to be contributed by the different parties. This model was installed at the Post Office Research Station, Dollis Hill, and shown to the Press in November 1959. Highgate Wood exchange differs from the model in respect of its equipment practice and in some of its logical elements but the greatest change is in respect of the automatic routining and security features now integrated into the system; these the model did not possess.

PRINCIPLE OF T.D.M. SWITCHING

In time-division multiplex telephone exchanges the conversation paths or highways are time shared, i.e. each call is allotted a particular "time slot" or channel defined by a pulse train, and as each pulse in the train appears it is caused to sample the speech wave and is amplitude modulated by it so that a series of signals describing the speech wave is transmitted along the highway. In the switched-highways system the channels

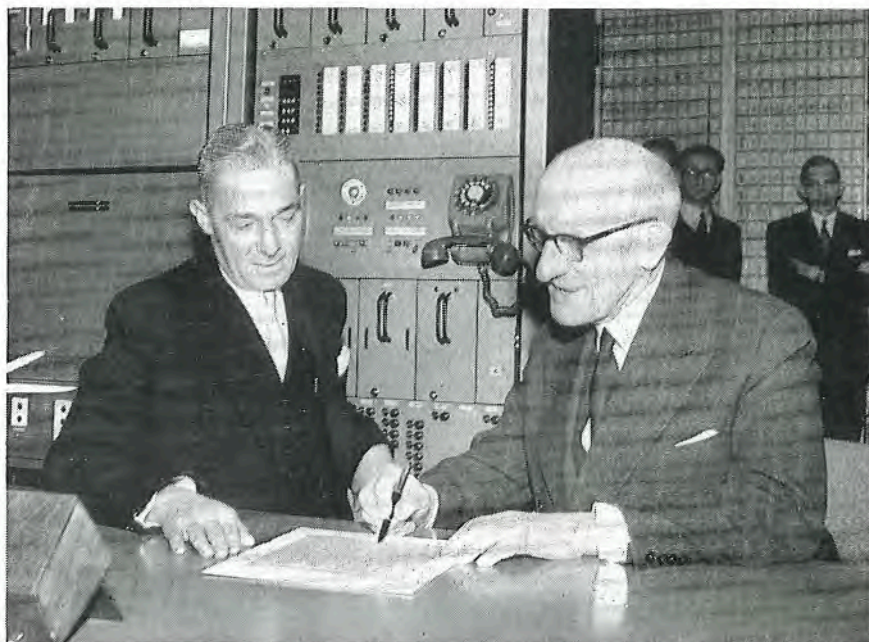

FIG.1—THE POSTMASTER GENERAL ACCEPTING HIGHGATE WOOD EXCHANGE FROM SIR THOMAS SPENCER

† Post Office Research Station.

are at $1\ \mu\text{s}$ separation and sampling occurs at $100\ \mu\text{s}$ intervals, giving a pulse repetition frequency of 10 kc/s and 100 channels in the multiplex. The principle is illustrated in Fig. 2. Speech from source A is sampled 10,000 times a second by pulse train P_a at modulator

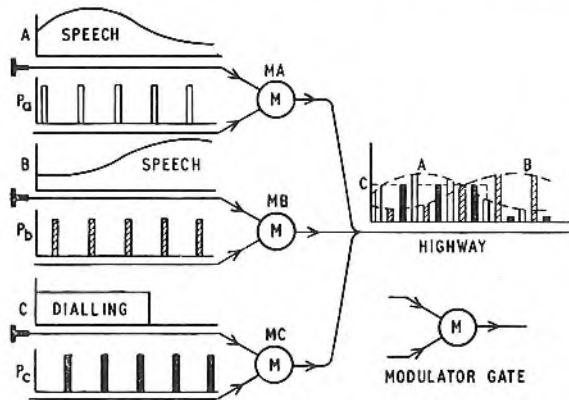

FIG. 2—PRINCIPLE OF TIME-DIVISION MULTIPLEX

gate MA, which is connected to the highway. Sources B and C are similarly sampled but by different pulse trains, P_b and P_c , the interleaved modulated pulses appearing on the common highway. The broken lines show the original waveforms that can be reconstructed from the modulated pulses at the receiving end of the system.

An exchange consists of a number of such highways, each highway serving a group of lines, i.e. subscribers and junctions. Since each highway in a multi-group system can carry between 60 and 65 Erlangs of traffic the number of lines in a group is variable from about 200 to 1,000; at Highgate Wood the maximum number is 800.

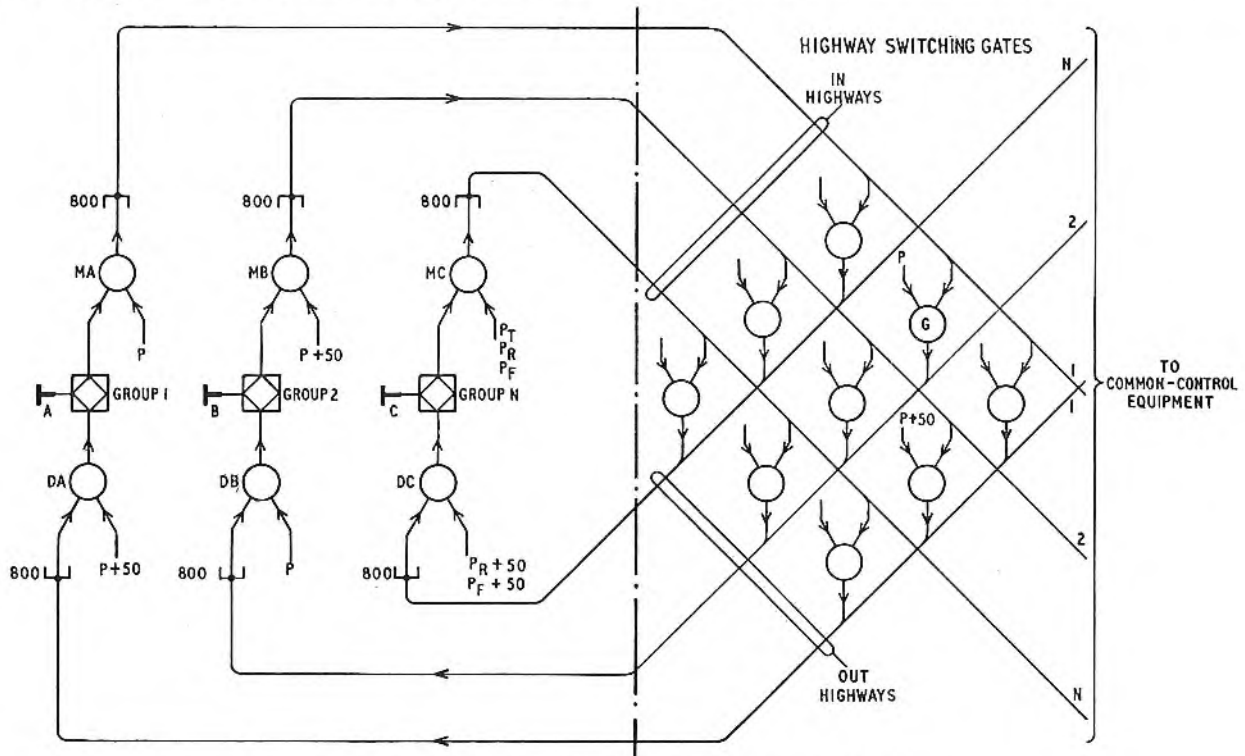

FIG. 3—BASIC TRUNKING FOR T.D.M. SWITCHED-HIGHWAYS SYSTEM

All the highways are fully interconnected by means of switching gates. Separate highways are used for inward and outward transmission so that each line requires a 4-wire/2-wire terminating set. The inward highway of each group is connected to the outward highway of every other group as shown in Fig. 3 which illustrates the basic trunking, omitting the setting-up apparatus and the controls.

A speech path from a subscriber in group 1 to a subscriber in group 2 using pulse channel P can be traced from modulator gate MA of the line A in group 1, via the inter-highway gate G, to demodulator gate DB of the line B in group 2. A similar path for the speech in the reverse direction can be traced via the gates operated at pulse time $P + 50$ (P and $P + 50$ mean a pair of pulses half the multiplex cycle time apart, i.e. 50 channel-pulse times apart; such pulses are said to be in antiphase). The reason for using a different pulse position for each direction of transmission is to avoid speech from either line being received by both and appearing as high-level sidetone in the speaker's instrument. Any pair of pulse trains would have served for this purpose but it is convenient to maintain a fixed relationship between them.

DESCRIPTION OF T.D.M. ELECTRONIC TELEPHONE EXCHANGE

To set up a speaking path in a t.d.m. switched-highway system it is clear that control and setting-up apparatus is necessary

- (i) to detect when a new call is initiated,
- (ii) to receive instructions dialled by the caller,
- (iii) to select the required line terminal,
- (iv) to select a pulse channel which is free and available to both the calling and called line, and
- (v) to establish the required connexion and maintain it until release conditions are signalled.

Control of Connexions

For an understanding of the system it is best to take the last of the above requirements first. Referring to Fig. 3, consider the path from subscriber A to subscriber B via the "in" highway of group 1 and the "out" highway of group 2, using channel time P. At any given time many other calls may be using the same highways and, therefore, although gate MA of subscriber A and gate DB of subscriber B must open only at channel time P, the inter-highway gate, G, must open not only at time P but also at each of the channel times which may have been allotted to other calls between the two groups. Hence, each gate in the transmission path must be controlled by a device which can store information relating to the pulse trains to be applied to the gate. It is advantageous if such a device can also generate the pulse trains.

At Highgate Wood these devices, which are known variously as memories or stores, take the form of magnetostriction delay lines, one of which is shown schematically in Fig. 4. A short pulse at the input to the write gate is amplified and applied to an input coil, W,

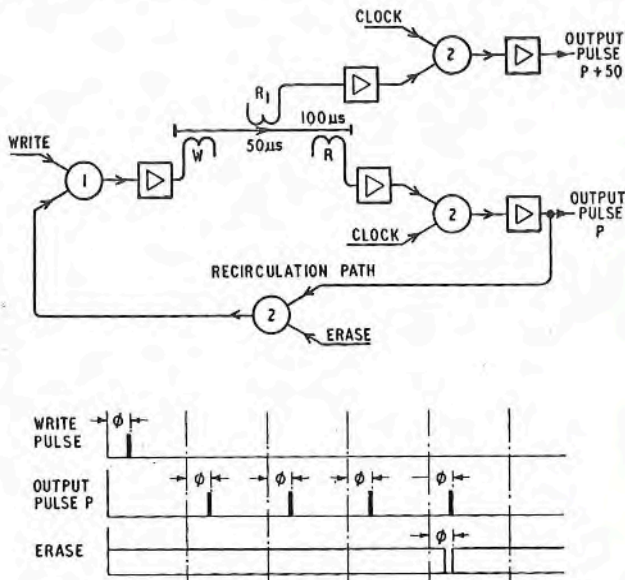

FIG. 4—SCHEMATIC DIAGRAM OF CIRCULATING DELAY LINE

at one end of a wire having magnetostrictive properties, producing a stress wave which travels down the wire and is detected $100 \mu\text{s}$ later at the output coil, R. An auxiliary coil R_1 is placed at the centre of the wire to detect the pulse $50 \mu\text{s}$ after it has been written. The output from coil R is amplified, re-timed by a strobe pulse and caused (a) to provide an output to the appropriate gate and (b) to provide a feed-back input to the write gate. Thus, any pulse injected once in the write coil will continue to circulate indefinitely, providing an iterative output from coils R and R_1 . Up to 100 pulses can circulate in this way. To erase any one of the pulses, i.e. to release any connexion controlled by the delay line, the recirculation path is broken at the erase gate for the duration of the appropriate pulse time. The remaining pulses will, however, continue to circulate.

Detecting Calls and Setting-Up Connexions

The incoming lines are continuously scanned to detect new calls. Scanning consists of applying a test pulse

to each of the modulator gates in turn in order to detect the condition of the line. One of the channel pulse times is reserved for use as a test pulse. If, when the line is being scanned, a new call has started the test pulse is gated on to the highway. The detection of this condition in the common-control equipment causes the caller to be connected to a register. The scanning and call-detection process therefore involves control of the line gates and, hence, of the delay-line stores which control them.

Since it is uneconomical to provide an individual delay line for every subscriber's line circuit, a system of coding is used. At Highgate Wood there are 800 lines in a group, which is divided into 8 sub-groups of 100 lines each, arranged in 10 rows of 10 columns. A line equipment position in any group can therefore be defined as a 3-digit number, ZXY , Z defining the sub-group, X the column and Y the row. Using five delay lines per digit and coding their outputs in two-out-of-five code a total of 15 delay lines can be made to serve the line gates of the 800 equipment positions. Fig. 5 illustrates the co-

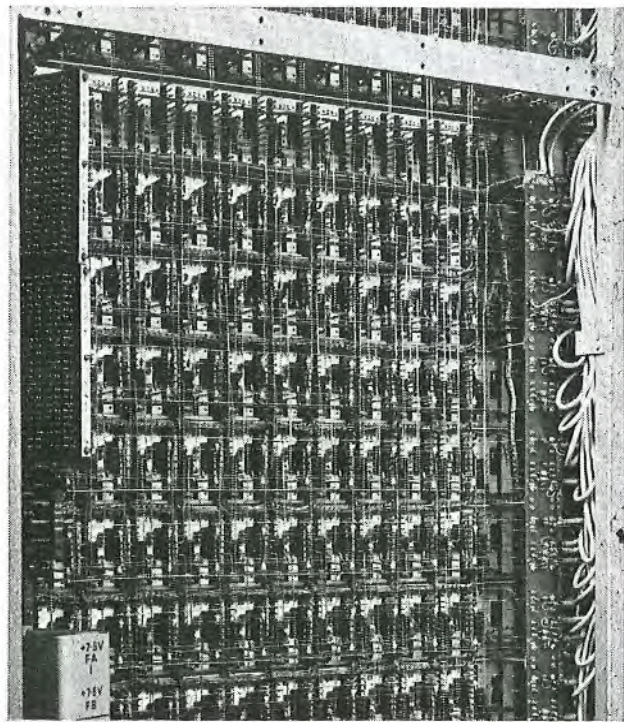

FIG. 5—CO-ORDINATE WIRING USED FOR CONNEXION OF LINE EQUIPMENTS

ordinate-wiring method used for the connexion of line equipments within a 100-line sub-group, and Fig. 6 shows the transmission racks containing line units, highway apparatus and delay-line stores.

The relationship between the subscribers' numbers and their exchange-equipment positions, given by the intermediate distribution frame cross connexions in existing exchanges, is, in this exchange, written into and stored on a magnetic drum. Each track of the drum is divided into 100 parts, one for each line in a sub-group. Four tracks are allocated for each sub-group and each group of tracks is switched sequentially so that as the

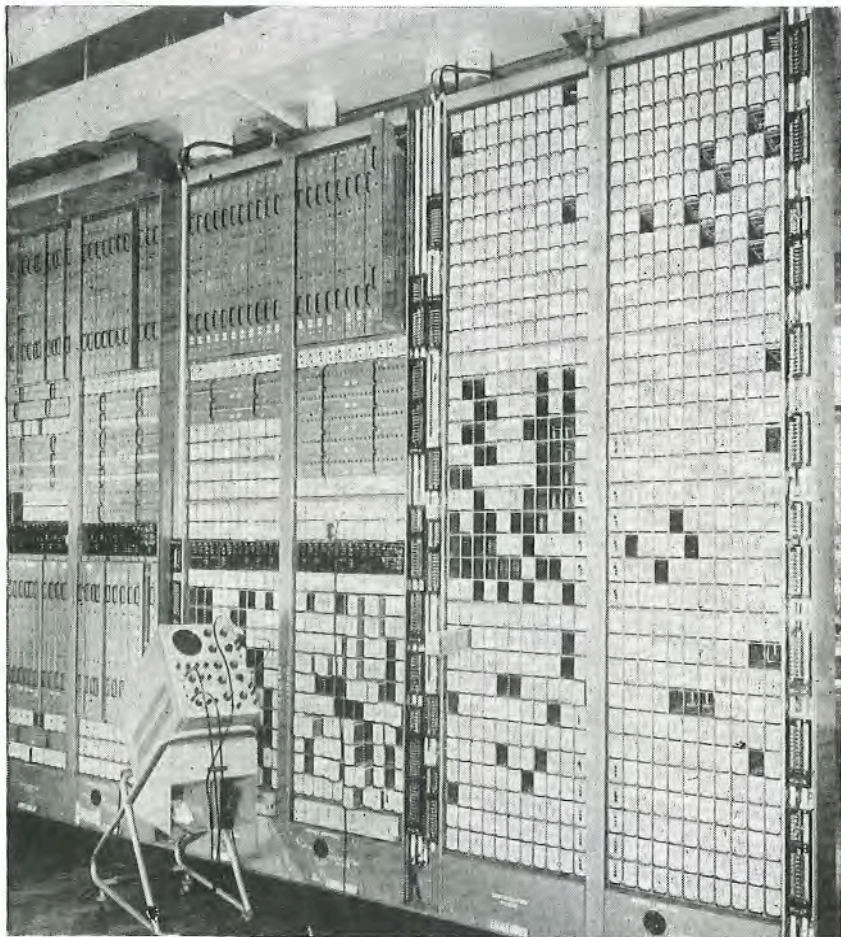

FIG. 6—TRANSMISSION EQUIPMENT RACKS

drum rotates the information relating to each of the equipment numbers, e.g. directory number, class of service, type of line, etc., appears in a fixed sequence at the output of the drum reading heads. That is, the position of the drum at any instant defines the equipment number ZXY of a particular line. Since the drum takes 28 ms to complete a revolution the information for each line is available for $280\mu\text{s}$ every 8×28 ms, i.e. 224 ms. (This is the scanning time for subscriber's lines, junctions being scanned at every revolution of the drum).

Fig. 7 shows the principles of line scanning and line selection for one of the groups. The delay lines are arranged in three groups of five delay lines each; of these, only one delay line in the Y set is shown, but the remaining 14 are identical. Each set of delay lines is connected to two decoding matrices one of which is fed from the centre tap of the delay lines. The decoding matrices convert the two-out-of-five combinations into the one-out-of-ten signals necessary to define the line gates.

As the drum revolves it generates waveforms corresponding to the ZXY code of the line it is scanning; these waveforms send signals on six out of 15 leads typified by lead A in the figure. Providing the line is not already engaged as the result of a previous scan a test-pulse generator supplies a test pulse P_T to gate G2. This pulse appears on the outputs of the G1 gates of each of

the six marked delay lines. These outputs are decoded, and, in the case of the X and Z leads, combined to select (a) the line gate, LG, of the subscriber's line circuit as defined by the sub-group Z and the column X, and (b) the gate YG appropriate to the row of 10 line equipments of which the scanned subscriber is one. Only if the subscriber's line, L, is looped is the test pulse permitted to be gated on to the in-highway, and, when the test pulse does so appear, the common-control equipment detects it and prepares to set up the call to a register. This process, which takes about $90\mu\text{s}$, occurs during the first half of the $280\mu\text{s}$ available in the scanning period. During scanning, the test pulse is prevented from circulating in the delay line by a signal over wire B, which inhibits the circulating path at the test-pulse time. As soon as a call has been detected a busy condition is written on the drum to prevent any set-up being attempted during subsequent scanning times.

When a connexion is to be set up the calling line's ZXY code from the drum is staticized* on six out of 15 leads, typified by lead C in Fig. 7. A device known as the channel selector sends a suitable pulse over the common lead E. This pulse will circulate in the particular set of six of the 15 delay lines and, as a result, pulse signals will appear on the six connect-inward leads and on the corresponding six connect-outward leads appropriate to a particular line. These signals are

combined in their respective decoders and are caused to operate the gates connecting the line to its highways. The selected pulse will continue to circulate in the delay line until the end of the call when it is erased by a pulse signal applied on lead B. As long as the pulse continues to circulate, the line L is connected to its in-highway at the selected pulse time, e.g. time pulse P, but because of the centre-tap output from the delay line, line L is connected to the out-highway $50\mu\text{s}$ out of phase, i.e. at time pulse $P + 50$.

The channel selector is simply a device which, on receiving a request to set up a connexion, selects the first free channel available in the group concerned. The group with which it has to deal is defined by the position of the drum, and the channels already in use in the group are signalled to the selector over the busy-channel lead (Fig. 7), to which is applied all the pulses circulating in the delay lines of the group concerned.

The channel selector also controls the delay lines controlling the setting of the inter-highway gates in the switching networks.

Fig. 8 shows the magnetic drum and associated control equipment racks.

* Staticized—converted from a time sequence of states representing digits into corresponding space distribution of simultaneous states.

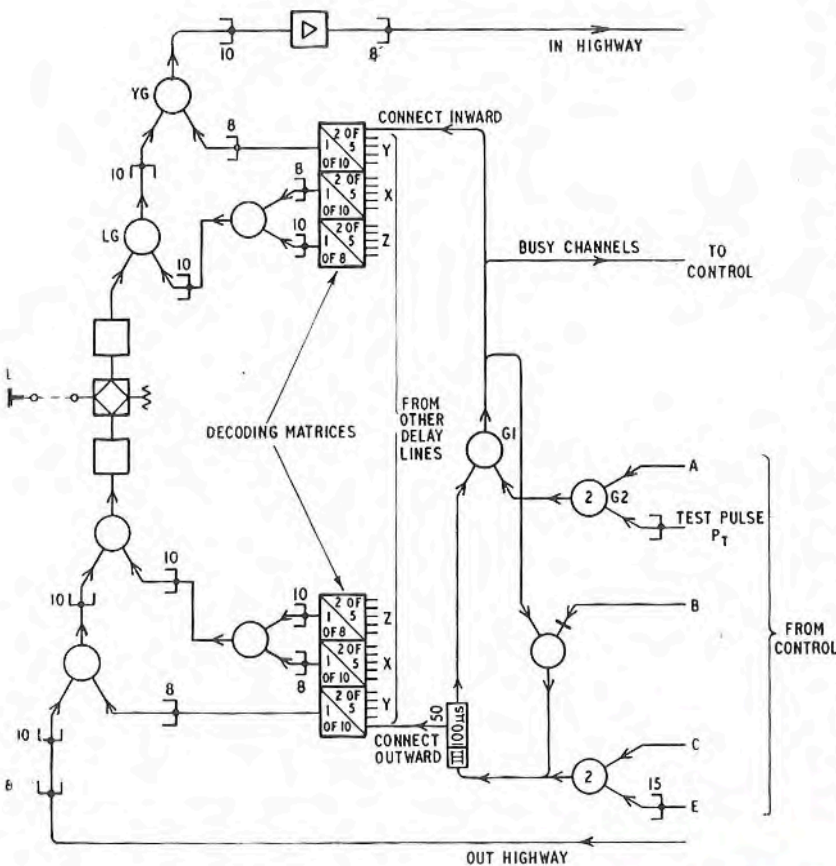

FIG. 7—SCHEMATIC DIAGRAM OF LINE-SCANNING AND LINE-SELECTION EQUIPMENT

Common-Control Equipment

The principles of the common-control equipment used in the system are illustrated by the schematic diagram of Fig. 9, which should be referred to in conjunction with Fig. 3.

Although in practice the various sections of the common control are physically separate pieces of equipment it is easier to follow the broad principles of the system if the common equipment be considered as being in two parts; (a) the control elements which control the setting up and clearance of the calls, receive and send information to and from the lines, and monitor the lines during conversation, and (b) the central memory containing all the permanent and semi-permanent information relating to the lines and junctions, including the translations.

When a subscriber, such as subscriber C in group N (Fig. 3), originates a call, the test pulse P_T is received in the control over the state-of-line lead (Fig. 9). The channel selector, with the knowledge that this is a new call, will select a pulse channel such as P_R that is free both on the in-highway

of group N and the common register highway RH (Fig. 9). The common-control equipment sends a pulse at time P_R to a gate, TG, which opens at the coincidence of this pulse time with that of a group pulse G_{PN} , which defines the number of the group. The pulse enters delay line TD, where it circulates giving an output to modulator gate DG at pulse time $P_R + 50$. These pulses are modulated by dial tone and transmitted via the out-highway to the calling subscriber.

When the subscriber dials, his dial pulses interrupt the pulse train P_R on the in-highway at modulator gate MC (Fig. 3). The dial breaks are counted and stored in the register, which, after sufficient digits have been received, refers to the central memory. If the call is for an outgoing junction a translation is received together with the designation of the equipment number of the outgoing circuit, i.e. its position on the drum. For a local call no translation is required. While the drum is scanning the required equipment number the setting-up apparatus can select the outgoing circuit and set the line gates to open at the pulse time of a channel which the channel selector finds is available on both the calling and called lines' highways. For a locally-terminated call the final connexion is then set up, but for an outgoing-junction call, the highway switch is prevented from operating until the register ceases to send out. The final setting-up involves a change of pulse on the caller's highway so that three different channels may be used in

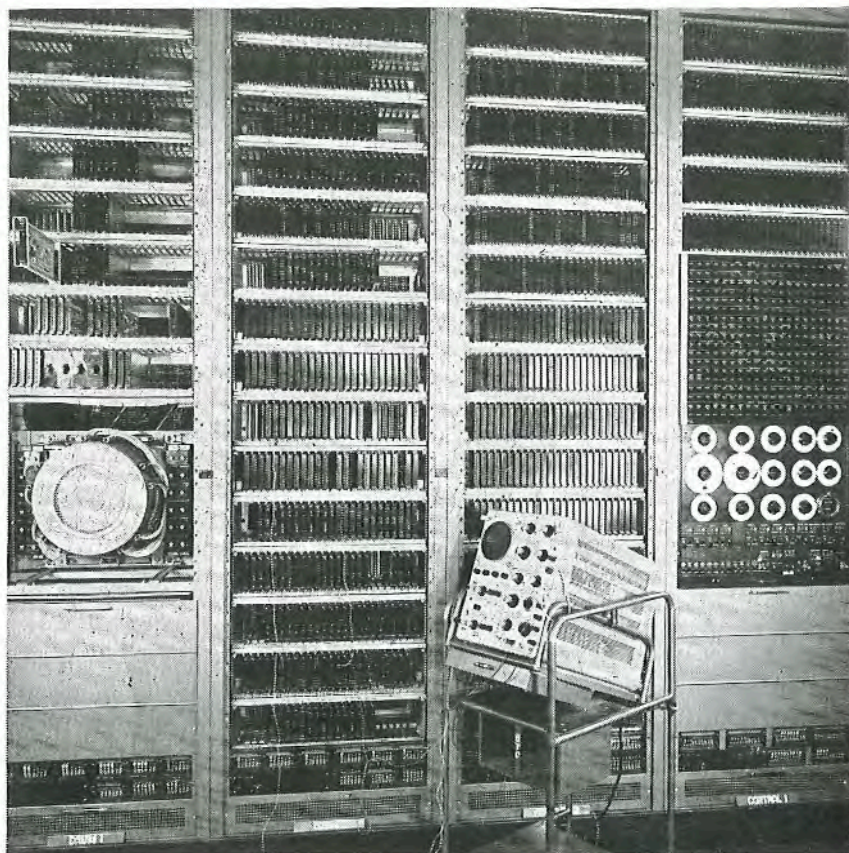

FIG. 8—MAGNETIC DRUM AND ASSOCIATED EQUIPMENT RACKS

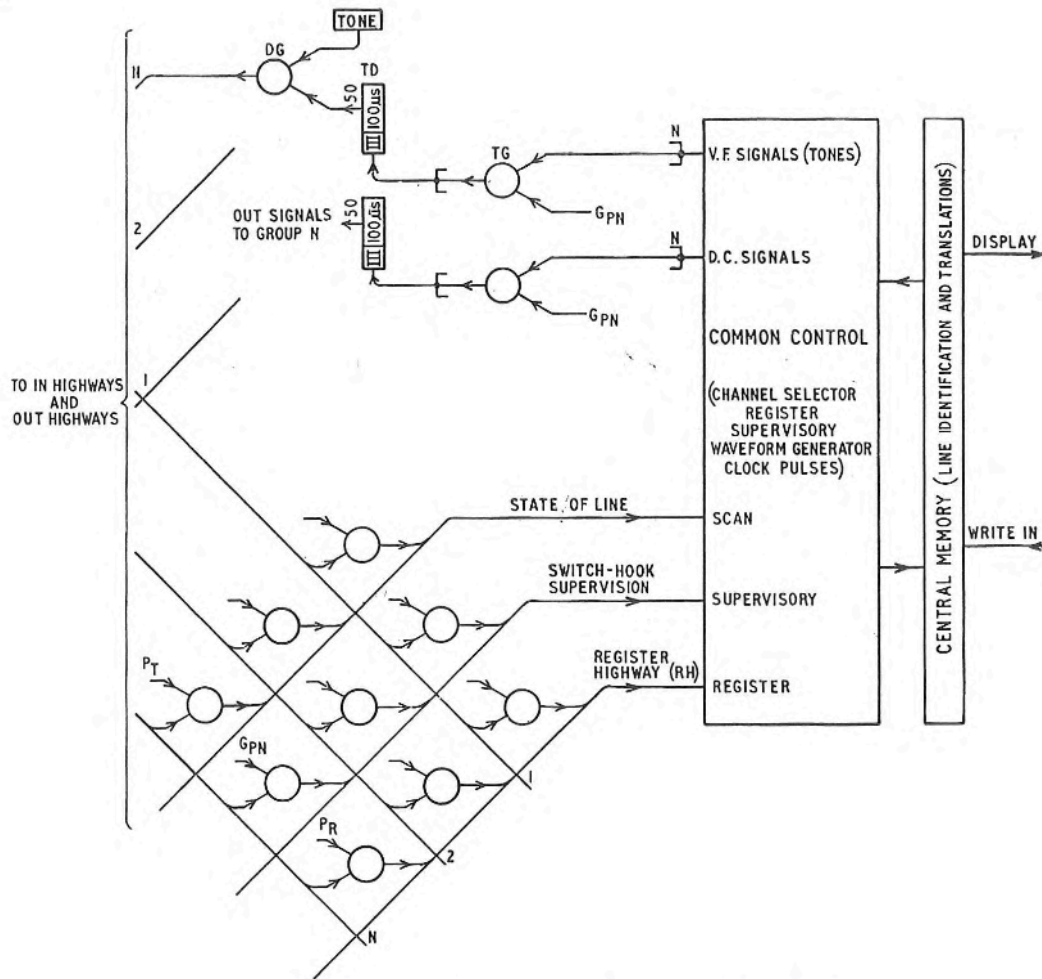

FIG. 9—SCHEMATIC DIAGRAM OF COMMON-CONTROL EQUIPMENT

succession while a call is being set up: a pulse P_T for detecting the call, a pulse P_R to make the register connexion, and a pulse P_V to complete the conversation path. Of these pulses only pulse P_T is fixed and not available for all types of connexion.

Supervisory Equipment

All operations in the exchange are dealt with on a one-call-at-a-time basis, a feature made possible by the speed of operation of electronic components. In the supervisory equipment, which controls the application of tones and signals to the highway channels and which detects the answer and release conditions, each multiplex channel in the exchange is scanned for $1 \mu s$ at $900 \mu s$ intervals. The equipment at Highgate Wood uses a number of $900 \mu s$ delay lines in a parallel arrangement. These act as stores for all the information relating to the highway channels, each channel being given a particular time position in the stores. The equipment is thus capable of looking after 9×100 channels, i.e. a 7,200-line exchange having 800 lines per group. At each channel position in the stores there is recorded a coded pattern indicating the state of a particular call. The pattern changes as the call progresses and logic-circuit elements deduce from these changes the action to be taken, e.g. to

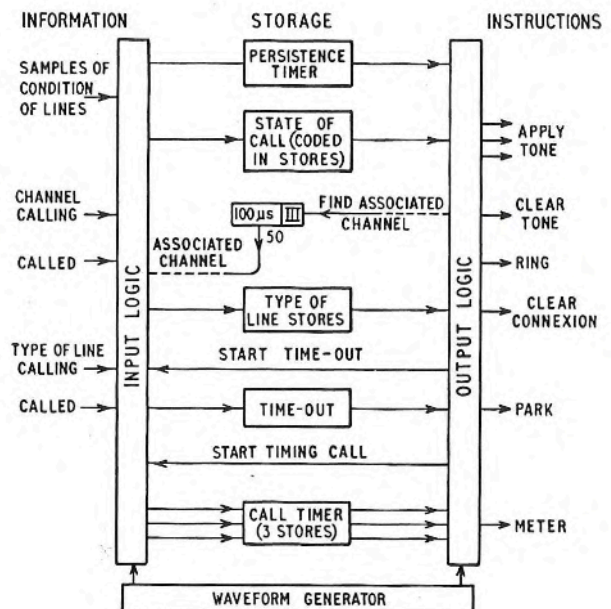

FIG. 10—ORGANIZATION OF SUPERVISORY EQUIPMENT

start or stop ringing, to meter the call or to initiate release of the call. These actions are in turn dependent on the class of service of the lines concerned, and because of this the information relating to the lines, which is permanently stored on the drum, is temporarily transferred to the supervisory equipment, where it is held in store until the connexion needing the information is cleared.

The equipment includes "persistence" timers, the equivalent of the well-known B-relay circuit. If a caller clears, his pulse train is removed from the highway although the gates in the connexion path continue to open at the channel time used by his call. When the supervisory equipment scans this channel it stores the "no-pulse" information and commences to "time out" the condition. If the clear persists long enough, the call is released by signalling from the setting-up apparatus to

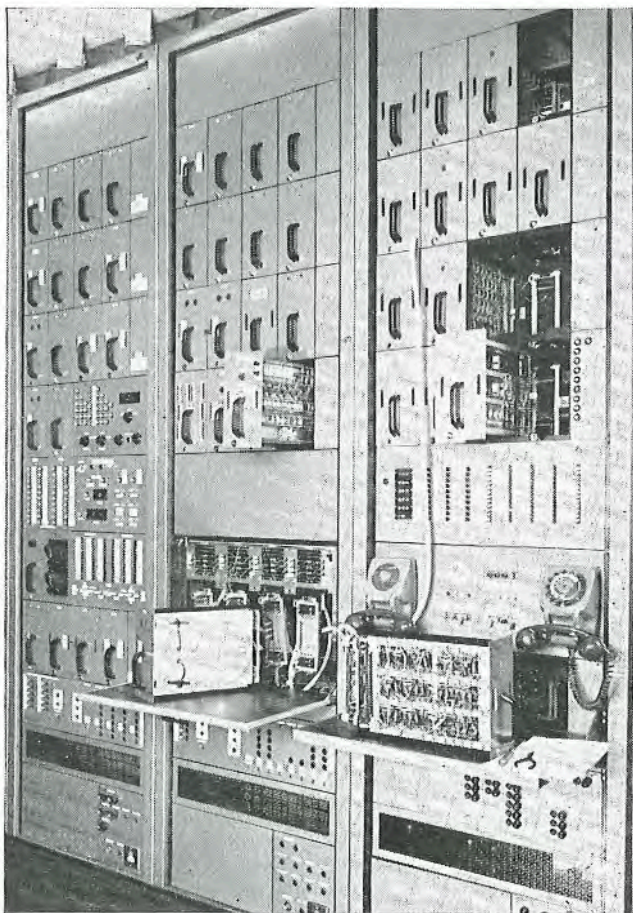

FIG. 11—SUPERVISORY EQUIPMENT AND EXCHANGE-FAULT ANALYSER EQUIPMENT RACKS

the inhibit gates in the circulating paths of the delay-line stores controlling the connexion. The organization of the supervisory equipment is illustrated in Fig. 10, the equipment being mounted on eight racks, two of which are shown at the left-hand side of Fig. 11.

Register

Like the supervisory equipment, the register (Fig. 12) also uses 900 μ s delay lines for storage purposes but in a

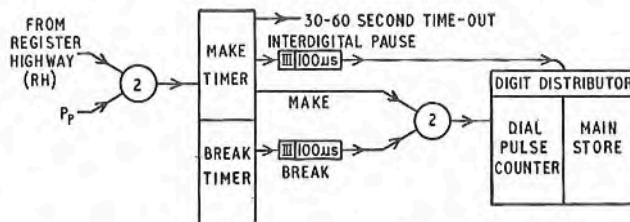

FIG. 12—ORGANIZATION OF REGISTER

different manner. The stores, which are arranged in groups of four, are divided into nine sections of 100 bits to provide 9-digit storage for 100 registers, each digit comprising 4 bits. The input to the register is the single register highway (RH in Fig. 9) over which dial pulses for 100 channels are received. The dial pulses are counted and scanned using 100 μ s delay lines before being stored serially at the channel-pulse time; an electronic digit distributor steers the dialled digits successively into sections 1, 2, 3, 4, etc., so that the wanted subscriber's number is stored in modified binary form at pulse times P_R , $P_R + 100$, $P_R + 200$, etc. Associated logical circuits process the call in accordance with the class of service and the digits dialled. Fig. 13 shows the register

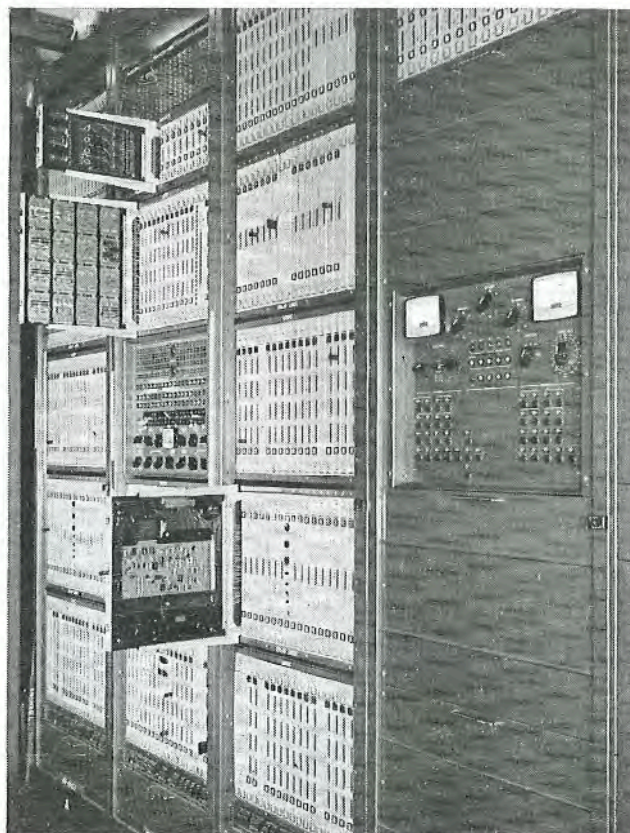

FIG. 13—REGISTER RACKS

racks, with a delay-line unit withdrawn near the bottom of one rack and associated equipment withdrawn higher up the racks to illustrate the sub-assembly construction of the equipment units.

MISCELLANEOUS FACILITIES AND EQUIPMENT

The exchange provides three-way connexions for trunk-offering and interception. Technically this means that an operator using one pulse-channel (P) and its antiphase (P + 50) must be able to speak and listen to a pair of subscribers using a different pair of channel pulses.

No test distributors are fitted, but the test clerk can dial through the exchange to select a line-isolating relay appropriate to the line it is required to test. This relay is necessary because no electronic switch gives the exact equivalent of the open-circuit condition demanded by the present method of line testing.

Because of the low power-handling capacity of electronic equipment it is not possible to transmit high-power ringing current through the exchange switches. Each line termination is therefore provided with a relay operated from a transistor pulse-lengthener which in turn is connected to a signalling highway. The signalling highway is trunked with and controlled in the same manner as the speech highways previously described, and it carries "d.c." signals (coded trains of unmodulated pulses) to control the line terminations (see Fig. 9). These signals, e.g. ringing and metering, are time shared and their cadences are controlled by a waveform generator.

All junctions are terminated in conversion equipments containing the relays necessary to provide such signals as line reversal and the means to repeat the pulse trains generated electronically by the registers.

The equipment provides "parking" facilities. When a line seizes the common equipment but the subscriber fails to dial, a timing-out circuit causes the calling signal to be taken off the highway and the magnetic drum records that this has been done. Lines indicated in this manner are interrogated at every scanning cycle to see if

the calling signal persists. The parking indication is removed from the drum when the call is cleared, but number-unobtainable tone (N.U.T.) is transmitted to the caller should he commence to dial before clearing the parking condition. Should the number of lines parked exceed a pre-set total an alarm is given.

The equipment also provides for timing a called-subscriber-held condition and releasing the subscriber, and facilities are provided for the subscribers' meter readings to be recorded on the drum, spare tracks being provided for this purpose. Fig. 14 shows part of the test rack and read-out printer for the meter records, etc.

SYSTEM SECURITY

Despite the experimental nature of this installation it has been designed to provide full service facilities and to carry public traffic under proper maintenance conditions. For this reason the security of the system, i.e. its ability to provide service in the presence of faults, has been carefully studied. At the same time, because little is known of the operation of electronic telephone exchanges in service, the opportunity has been taken of trying out several possible approaches to the problem of maintaining a continuous service.

Although most of the testing routiners can be manually controlled they normally operate continuously, "system time" being allocated for the testing cycles. Thus, certain line positions in each of the sub-group tracks of the drum are allocated for test words, and while these words are being scanned no new call can be set up. The test words cause a particular sub-routine to be initiated and checked, each word covering a limited number of operations, e.g. the initial set-up of a connexion to a register. Such tests may involve every section of the exchange. Other test words are used by the drum equipment for local tests of its own logic circuits.

The transmission highways are completely duplicated and are used alternately every 30 seconds. The path not in use is checked by a routiner. If a fault is detected the change-over is inhibited.

Only one magnetic drum is provided but this has spare tracks which can be switched in as required. The groups of line-connecting stores use the principle of "1-in-*n* sparing," i.e. each group is equipped with an additional spare delay line which can be switched in place of any of the others in the group, the testing and switching being under the control of a routiner. Otherwise the functional sections of the equipment are provided in duplicate: a working section, A, and a spare section, B.

For the register and the supervisory equipments, inputs from the system to the A and B sections are commoned and both sections operate continuously in parallel. For the supervisory equipment the A and B outputs are also commoned, and comparators check that both sections are giving the same digital output, which at any instant should be either a 1 or an 0. If a discrepancy is detected the section giving the 1 output is switched out of service and the equipment left in service is checked by the routiner.

The routiner has two interlocked cycles, one to check the basic operation of the equipment every few seconds and the other to test facilities, such as time-out and metering, for which a much longer time cycle is necessary.

The register routining arrangements are similar except that the outputs from the A and B sections, although continuously compared, are not both commoned to the

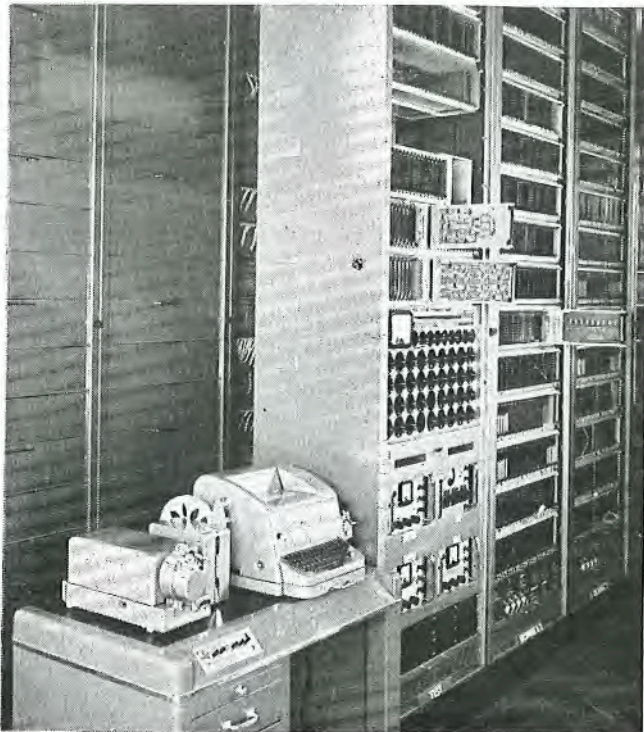

FIG. 14—TEST RACK AND READ-OUT PRINTER

outputs to the system. The routiner's test cycle enables it to test the functional operations of both equipments, e.g. the operation of the delay-line stores, while the registers are carrying live traffic.

The control equipment for the drum is designed to cater for a three-group system but, since the exchange is opening with a single group, each of the group equipments of the drum is arranged to deal with one third of the subscribers' lines. In addition a fourth equipment is provided as a standby that can be switched in place of any of the others in the event of a fault.

In the exchange as a whole, some routiners may be performing functional tests of the section of the equipment they serve while others are testing the system during system time. With this routing method, and having regard to the complexity of the information-exchange paths interconnecting the various parts of the system, it is inevitable that a single fault may be indicated by more than one routiner. For this reason all indicated faults are referred to an exchange-fault analyser (right-hand rack in Fig. 11), which analyses the information it receives and decides on the appropriate action to take. This may involve resetting certain of the routiners and the initiation of a series of tests in a preferred order, checking that the appropriate spare equipment has been switched in, and inaugurating a series of test calls. Catastrophic failures, if any occur, will result in the exchange being switched to the electromechanical standby.

EQUIPMENT AND COMPONENTS

The equipment is mounted on 10 ft 6 in. racks, each suite of racks being terminated by an end panel housing the power distribution for the suite. The tops of the racks are connected by hoses to the ventilation trunking, through which the hot air is exhausted by means of ventilation fans; this feature is necessary because of the large numbers of hot valves employed in the system, design having commenced in 1956 before sources of reliable transistors were available.

Various types of equipment modules have been used. This is to some extent dependent on whether valve or transistor circuits have been used, but, in addition, the opportunity has been taken to try out different types of equipment practice. In some instances equipment units consist of similar circuit elements, e.g. toggles or gates, these being interconnected by cross wiring at the back of the racks to give the required circuit sequence. In other cases the equipment giving a complete facility is wired as a unit or made up from an assemblage of small unit cards.

Since equipment practice can profoundly affect not only the factory production but also the ability to trace and clear faults when the equipment is in service it is obviously desirable that these various ideas should be subject to field trial.

The table shows the approximate total numbers of the various electronic components used.

Electronic Components Used at Highgate Wood
Electronic Exchange

Valves	3,000
Transistors	26,000
Diodes	150,000
Resistors	148,000
Capacitors	50,000
Total Components	377,000

These totals are, of course, far in excess of the actual requirements for Highgate Wood; this is due to the scope of the experiment specified when the development was first authorized. So far the failure rate of the components appears to be low and, although up to the present many of the failures can be attributed to "working-party faults," a fault rate of less than 1 per 2,000 components per annum is confidently expected.

INSTALLATION

Deliveries of the equipment commenced early in 1961, the last rack being received in August of that year. In the course of the design and manufacture it was decided that, since the operation of a multi-group system had been proved on the model at the Post Office Research Station, it would be sufficient initially to provide a single-group transmission system for Highgate Wood but, apart from this, most of the common control would be capable of serving a very large exchange.

The commissioning of the equipment was undertaken by a team which included representatives from each member organization of J.E.R.C. Due to the wide variety of techniques and equipment practice involved and the diversity of the common-control apparatus, the task of the team was many times more arduous than the normal commissioning of an established system. Nevertheless the work was accomplished in about the same time that it would have taken to install standard equipment, and the first effective call from a standard subscribers' station was passed through the exchange on 25 September 1962.

CONCLUSION

During the design and construction of this experimental equipment many lessons have been learned which will prove of great value in the design of future electronic systems. So far the component failure rate has been very low, and although fault tracing is not easy it is clear that substantial improvements in this respect will be possible in future designs.

In a developing art such as electronic switching, rapid developments of new techniques and components are to be expected and already much of the Highgate Wood equipment is obsolescent. Nevertheless the skill and knowledge now acquired by the telecommunications industry could not have been gained except from the experience of building and commissioning a working exchange.

ACKNOWLEDGEMENTS

The successive stages of the development—the research, the system, circuit and equipment design, and the installation and commissioning have all been jointly undertaken by teams drawn from each member organization of J.E.R.C. This has involved close and continuous co-operation at all levels of the joint organization, and acknowledgement must be made of the unstinted support given by all concerned.

The transmission apparatus, including the line stores, was designed by The General Electric Co., Ltd., the drum apparatus was designed jointly by Automatic Telephone & Electric Co., Ltd., and Standard Telephones & Cables, Ltd., the supervisory equipment was designed by Ericsson Telephones, Ltd., the register was designed by Associated Electrical Industries, Ltd., and the exchange-fault analyser by the Post Office Engineering Department.

The author desires to thank his colleagues in the Post Office and the telecommunications industry for their assistance in the preparation of this article and for their cooperation in the great task of getting the exchange into service.

Bibliography

HARRIS, L. R. F. Time Sharing as a Basis for Electronic Telephone Switching. A Switch-Highways System. *Proceedings I.E.E.*, Paper No. 1993R, Mar. 1956 (Vol. 103, Part B, p. 722).

BROADHURST, S. W. An Experimental Electronic Telephone Exchange. *Post Office Telecommunications Journal*, Vol. 12, p. 59, Spring 1960.

HARRIS, L. R. F. Highgate Wood Experimental Electronic Telephone Exchange. General System Description. *British Communications & Electronics*, Vol. 7, p. 897, Dec. 1960.

CAPLIN, J. S. Highgate Wood Experimental Electronic Telephone Exchange. The Transmission Paths and Line Equipment. *British Communications & Electronics*, Vol. 7, p. 900, Dec. 1960.

SIMMONS, B. D. Highgate Wood Experimental Electronic Telephone Exchange. The Register Equipment. *British Communications & Electronics*, Vol. 7, p. 904, Dec. 1960.

ALLUM, R. D., and KNIGHT, R. G. Highgate Wood Experimental Electronic Telephone Exchange. Magnetic Storage Drum Control. *British Communications & Electronics*, Vol. 7, p. 907, Dec. 1960.

MARTIN, A. D. Highgate Wood Experimental Electronic Telephone Exchange. Supervisory Equipment. *British Communications & Electronics*, Vol. 7, p. 910, Dec. 1960.

Various papers relating to Highgate Wood experimental electronic telephone exchange presented at the Conference on Electronic Telephone Exchanges, November 1960. *Proceedings I.E.E.*, Vol. 107, Part B, Supplement No. 20, 1960.
