



DIAL



N.4381.

INFORMATION FOR SHOPS

FORMERLY DRG 21600.

TO BE ASSEMBLED, ADJUSTED, & TESTED IN ACCORDANCE WITH INSPECTION INSTRUCTION TA 116 (APPENDIX I), FOR N4381 M. AUSTRALIA.)



FIG 1

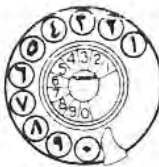

FIG 2



FIG 3



FIG 4



FIG 5

DIAL FOR USE ON AUTOMATIC TELEPHONES. ALSO SWITCHARDS WORKING TO ALTERNATE FREQUENCIES. TYPE IN EXCHANGE TO BE STATED WHEN SPEERING.

WIPAGE WHEEL MARKED A 3 VES 10 IMPULSES PER SECOND BREAK PERIOD BEING 25% OF THE TOTAL IMPULSE PERIOD. THIS WHEEL IS INTERCHANGEABLE WITH OTHER WHEELS GIVING A DIFFERENT RATE.

FIXING SCREW - PART N° 36
STANDARD - ROUND HEAD
TROPICAL - CAPSTAN HEAD

LABELS PART 9 ARE ONLY TYPICAL

ON DIALS WITH MOULDED FINGER PLATE PARTS 10 14-26-37 REPLACED BY 47

HOLES REAMED 0.015" DIA.
0.005"

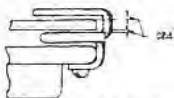
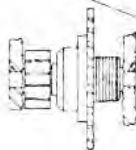

VIEW SHOWING DIMENSION CLEARANCE TO BE OBTAINED BETWEEN FINGER TOP & FINGER PLATE

WHEN DUST COVER IN HOUSING (PART N° 46) IS REQUIRED, THE CONNECTION SCREWS (PART N° 40) CALLED FOR ON THE SPRING SET ARE TO BE ALTERED FROM N. 10885 TO SS X 48 COM N° 40 FLAT END (SEE N. 4381A)

EDGES OF INSULATORS ON SPRINGSET TO BE VARNISHED IN ACCORDANCE WITH APP. CIRC. 126

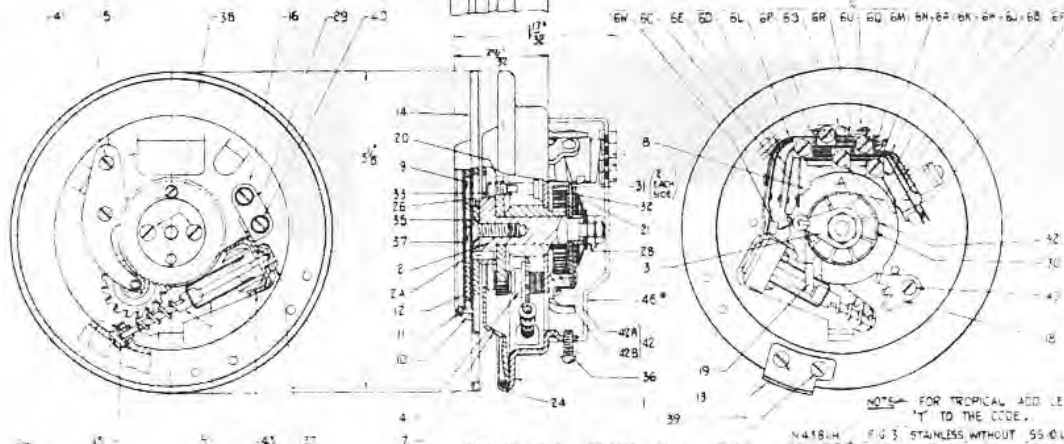

FRONT VIEW WITH FINGER PLATE A
NUMBER RING REMOVED.

* THE COLUMN REFERRING TO COVER (PART N° 46), APPLIES TO DIALS HAVING STANDARD FINISH. ALL TROPICAL DIALS ARE FITTED WITH COVERS.

NOTE: FOR TROPICAL ADD LETTER 'T' TO THE CODE.

N4381W	FIG 3	MOULDED	WITH	IOLA
N4381U	FIG 5	MOULDED	WITH	CHINESE
N4381S	FIG 5	STAINLESS	WITH	CHINESE
N4381R	FIG 1	MOULDED	WITH	EGYPT
N4381Q	FIG 2	MOULDED	WITH	EGYPT
N4381P	FIG 1	MOULDED	WITHOUT	
N4381M	FIG 1	STAINLESS	WITHOUT	AUSTRALIA
CODE	MARKING	FINGER PLATE	COVER PART 46	PO & OTHER CUST. CODE

N4381H	FIG 3	STAINLESS	WITHOUT	SS 10LA MK 44
N4381F	FIG 1	STAINLESS	WITHOUT	SS 10 FA MK 44
N4381E	FIG 3	STAINLESS	WITHOUT	SS 10 LA MK 796 A
N4381D	FIG 4	STAINLESS	WITHOUT	NEW ZEALAND
N4381C	FIG 1	STAINLESS	WITHOUT	SS 10 FA MK 796 A
N4381B	FIG 3	PHOS BZE	WITHOUT	IOLA MK 235
N4381A	FIG 2	STAINLESS	WITH	EGYPT
N4381	FIG 1	PHOS BZE	WITHOUT	10 FA MK 235
CODE	MARKING	FINGER PLATE	COVER PART 46	PO & OTHER CUST. CODE

APPROX WEIGHT: 7.2 OZ

SCALE

N4381K (WAR TIME
N4381J) SUBSTITUTES

159.3
 7 18555
 206 15400
 224 1290
 24 55496
 25 27828
 27 26093

APPROVED
 31-7-51
 STOCKISTS CN. N° 2
 N.4381.



DIAL - AUTO (TRIGGER TYPE)

N4383A|ETC

SHEET 2.

INFORMATION FOR SHOPS



FIG. 1

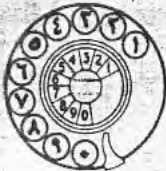

FIG. 2



FIG. 3



FIG. 4



FIG. 5



FIG. 6

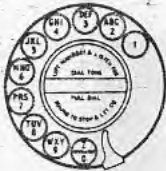

FIG. 7



FIG. 8

CODES SEE SEPARATE SHEETS.

APPROX. WEIGHT :-

SCALE

ISSUE N° 2

APPROVED	STOCKLIST	CN. N°
	N4383A ETC	ET
	SHEET 2	



DIAL - AUTO (TRIGGER TYPE)

N4394AIA SHEET 2 ETC.

INFORMATION FOR SHOPS

CODE	COLOR OF FINGER PLATE	TYPE OF FINGER PLATE	COLOR OF PART NO 42	MARKING OF PART NO 42	SPEED IN IMPULSES/SEC	BREAK/MAKE RATIO	LABEL PART NO 48	P. O. CODE
N4394AIA	BLACK	P. V. C.		NON-DIR.	10	66 $\frac{2}{3}$:33 $\frac{1}{2}$	N95601	
N4394AAIA	BLACK	MOULDED		NON-DIR.	10	66 $\frac{2}{3}$:33 $\frac{1}{2}$	N95601	
N4394AAIB	BLACK	MOULDED		NON-DIR.	10	60:40	N95601	
N4394A2A	BLACK	P.V.C.		DIRECTOR	10	66 $\frac{2}{3}$:33 $\frac{1}{2}$	N95601	21 LA (BLACK)
N4394AA2A	BLACK	MOULDED		DIRECTOR	10	66 $\frac{2}{3}$:33 $\frac{1}{2}$	N95601	
N4394AA3A	BLACK	MOULDED		NEW ZEALAND	10	66 $\frac{2}{3}$:33 $\frac{1}{2}$	N95601	
N4394AA5A	BLACK	MOULDED		ENGLISH & EGYPTIAN	10	66 $\frac{2}{3}$:33 $\frac{1}{2}$	N95601	
N4394AA5B	BLACK	MOULDED		ENGLISH & EGYPTIAN	10	60:40	N95601	
N4394AA6A	BLACK	MOULDED		ENGLISH & CHINESE	10	66 $\frac{2}{3}$:33 $\frac{1}{2}$	N95601	
N4394AIIA	BLACK	P. V. C.	BLACK	WHITE CHAPLETS	10	66 $\frac{2}{3}$:33 $\frac{1}{2}$	N95601	21 CA (BLACK)
N4394AIIA	BLACK	MOULDED	BLACK	WHITE CHAPLETS	10	66 $\frac{2}{3}$:33 $\frac{1}{2}$	N95601	
N4394AIIB	BLACK	MOULDED	BLACK	WHITE CHAPLETS	10	60:40	N95601	
N4394AIIID	BLACK	MOULDED	BLACK	WHITE CHAPLETS	10	61 $\frac{1}{2}$:38 $\frac{1}{2}$	N95601	
N4394AASC	BLACK	MOULDED		ENGLISH & EGYPTIAN	8-9	60:40	N95601	
N4394AAD	BLACK	MOULDED		NON-DIR	10	61 $\frac{1}{2}$:38 $\frac{1}{2}$	N95601	
N4394AAIH	BLACK	MOULDED		NON-DIR	10	61 $\frac{1}{2}$:38 $\frac{1}{2}$	N95601	
N4394AA2N	BLACK	MOULDED		DIRECTOR	10	66 $\frac{2}{3}$:33 $\frac{1}{2}$	N95601	
N4394AA26A	BLACK	MOULDED		NEW ZEALAND WHITE CHARS.	10	66 $\frac{2}{3}$:33 $\frac{1}{2}$	N95601	
N4394AA10A	BLACK	MOULDED		CANADIAN DIRECTOR	10	66 $\frac{2}{3}$:33 $\frac{1}{2}$	N95601	
N4394AA2IA	BLACK	MOULDED		CANADIAN DIRECTOR	10	66 $\frac{2}{3}$:33 $\frac{1}{2}$	N95601	
N4394BA1A	IVORY	MOULDED		NON-DIR.	10	66 $\frac{2}{3}$:33 $\frac{1}{2}$	N95601	
N4394BA2A	IVORY	MOULDED		DIRECTOR	10	66 $\frac{2}{3}$:33 $\frac{1}{2}$	N95601	
N4394BA5A	IVORY	MOULDED		ENGLISH & EGYPTIAN	10	66 $\frac{2}{3}$:33 $\frac{1}{2}$	N95601	
N4394BA5B	IVORY	MOULDED		ENGLISH & EGYPTIAN	10	60:40	N95601	
N4394BA6A	IVORY	MOULDED		ENGLISH & CHINESE	10	66 $\frac{2}{3}$:33 $\frac{1}{2}$	N95601	
N4394B12A	IVORY	P. V. C.	IVORY	BLACK CHAPLETS	10	66 $\frac{2}{3}$:33 $\frac{1}{2}$	N95601	21 CA (IVORY)
N4394BA12A	IVORY	MOULDED	IVORY	BLACK CHAPLETS	10	66 $\frac{2}{3}$:33 $\frac{1}{2}$	N95601	
N4394BA12B	IVORY	MOULDED	IVORY	BLACK CHAPLETS	10	60:40	N95601	
N4394BA12D	IVORY	MOULDED	IVORY	BLACK CHAPLETS	10	61 $\frac{1}{2}$:38 $\frac{1}{2}$	N95601	

DO 43/P

ISSUE NO	1	2	3	4	5
----------	---	---	---	---	---

APPROVED
13 4 64

N4394AIA
SHEET 2